

XSPC-P9T9R-CN2C(I)

SFP+ MPM XGS-PON OLT N2/C+ Transceiver

Features

- Single fiber bi-directional data links TX 9.953Gbps, Burst Mode RX 9.953G/2.488Gbps application
- Single fiber bi-directional data links TX 2.488Gbps, Burst Mode RX 1.244Gbps application
- 0 to 70°C operating case temperature
- 3.3V power supply
- SFP+ package with SC Receptacle connector
- Hot-pluggable capability
- High power 1577nm EML LD and High power 1490nm DFB LD
- High sensitivity 1270nm/1310nm APD
- Support 20km transmission distance with SMF
- SD indication
- Low EMI and excellent ESD protection
- Digital diagnostic monitor interface
- RoHS10 compliance



Applications

- XGS-PON OLT N2
- GPON OLT C+

Standards

- Complies with SFF-8472
- Complies with ITU-T G.9807.1 and ITU-T G.987.2
- Complies with FCC 47 CFR Part 15, Class B
- Complies with FDA 21 CFR 1040.10 and 1040.11

Absolute Maximum Ratings

Table 1 - Absolute Maximum Ratings

Parameter	Symbol	Min	Max	Unit	Notes
Storage Ambient Temperature	TSTG	-40	85	°C	
Operating Case Temperature	TA	0	70	°C	
Relative Storage Humidity	RHs	5	85	%	
Relative Operating Humidity	RoHS	5	85	%	
VCC3 Power Supply Voltage	VCC3	3.13	3.47	V	
Total Power			3.3	W	

Recommended Operating Environment

Table 2 - Recommended Operating Environment

Parameter	Symbol	Min	Typical	Max	Unit	Notes
Operating Case Temperature	Tc	0		70	°C	
Power Supply Voltage	Vcc	3.13	3.3	3.47	V	
RX Data Rate			9.953		Gbps	
			2.488			
			1.244			
TX Date Rate			9.953		Gbps	
			2.488		Gbps	

XGSPON Transmitter Optical Characteristics

Table 3-XGSPON Transmitter Optical Characteristics

Parameter	Symbol	Min	Typical	Max	Unit	Notes
Optical Center Wavelength	λ_C	1575		1580	nm	
Optical Spectrum Width (-20dB)	$\Delta\lambda$	-	-	1	nm	
Side Mode Suppression Ratio	SMSR	30			dB	
Average Launch Optical Power	AOP	+4		+7	dBm	Launched into SMF
Power-OFF Transmitter Optical Power				-39	dBm	Launched into SMF
Extinction Ratio	ER	8.2			dB	PRBS2 ³¹ -1 @9.953Gbps
Optical Waveform Diagram	Compliant with ITU-T G.9807.1					Figure 1, Mask Margin>5%
Tolerance to Transmitter Incident Light		-15			dB	
Transmitter and Dispersion Penalty	TDP			1	dB	Transmit on 20km SMF

XGSPON Transmitter Electrical Characteristics

Table 4-XGSPON Transmitter Electrical Characteristics

Parameter	Symbol	Min	Typical	Max	Unit	Notes
Data Input Differential Swing		100		850	mV	CML input, AC coupled
Input Differential Impedance	Zin	90	100	110	Ω	
TX Disable	Disable	2		VCC+0.3	V	
	Enable	0		0.8	V	
TX Fault	Fault	2.4		VCC+0.3	V	
	Normal	0		0.4	V	

XGS PON Transmitter Eye Mask Definitions And Test Procedures

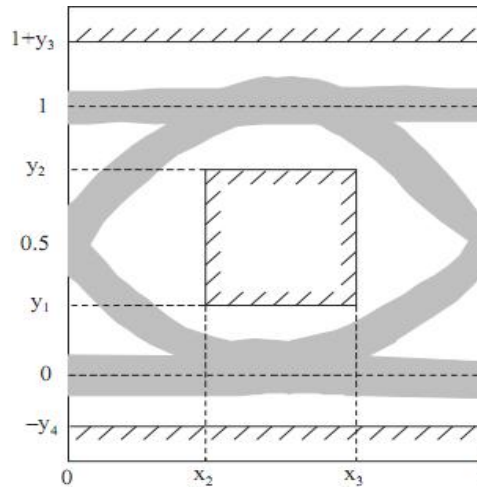

Figure 1 XGPON Transmitter Eye Mask Definitions

X3-X2	Y1	Y2	Y3	Y4	Unit
0.2	0.25	0.75	0.25	0.25	UI

GPON Transmitter Optical Characteristics

Table 5- Transmitter Optical Characteristics

Parameter	Symbol	Min	Typical	Max	Unit	Notes
Optical Center Wavelength	λ_C	1480		1500	nm	
Optical Spectrum Width (-20dB)	$\Delta\lambda$			1	nm	
Side Mode Suppression Ratio	SMSR	30			dB	
Average Launch Optical Power	AOP	+3		+7	dBm	Launched into SMF
Power-OFF Transmitter Optical Power				-39	dBm	Launched into SMF
Extinction Ratio	ER	8.2			dB	PRBS 2 ²³ -1+72CID@2.488G
Optical Waveform Diagram	Compliant with ITU-T G.984.2					Figure 2, Mask Margin>5%
Tolerance to Transmitter Incident Light			-15		dB	
Transmitter and Dispersion Penalty	TDP			1	dB	Transmit on 20km SMF

GPON Transmitter Electrical Characteristics

Table 6-GPON Transmitter Electrical Characteristics

Parameter	Symbol	Min	Typical	Max	Unit	Notes
Data Input Differential Swing		100		850	mV	CML input, AC coupled
Input Differential Impedance	Zin	90	100	110	Ω	
TX Disable	Disable	2		VCC+0.3	V	
	Enable	0		0.8	V	
TX Fault	Fault	2.4		VCC+0.3	V	
	Normal	0		0.4	V	

GPON Transmitter Eye Mask Definitions And Test Procedure

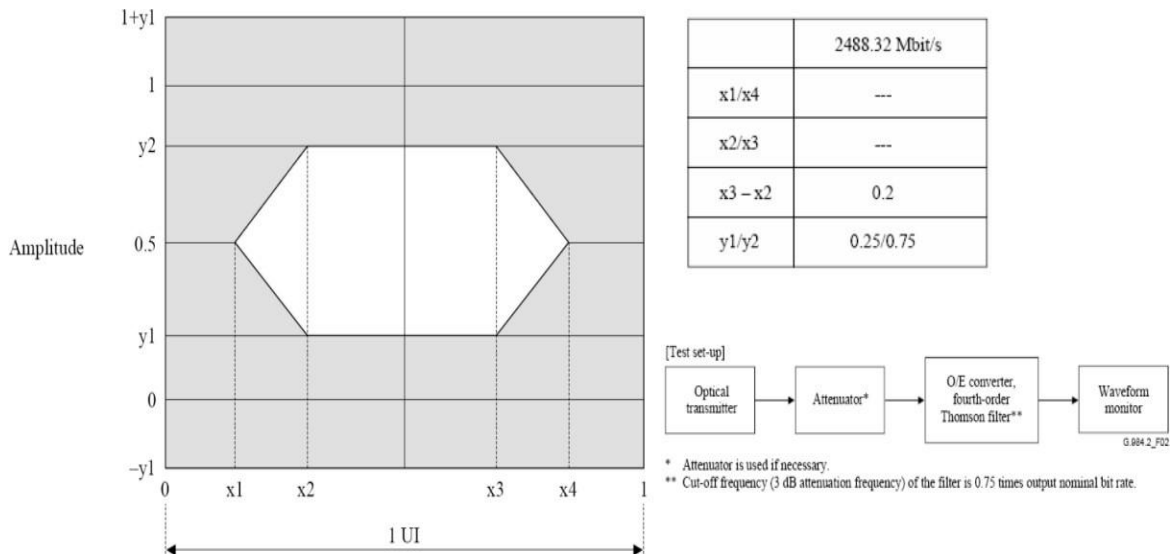

Figure 2 GPON Transmitter Eye Mask Definitions

XGS PON Receiver Optical Characteristics

Table 7-XGS PON Receiver Optical Characteristics

Parameter	Symbol	Min	Typical	Max	Unit	Notes
Operating Wavelength		1260		1280	nm	
Sensitivity	SEN			-28.0	dBm	ER≥6dB, PRBS2 ³¹ @9 .953Gbps BER ≤1×10 ⁻³
Minimum Overload		-7			dBm	
Max Optical input				0	dBm	
SD Assert Level				-28.5	dBm	
SD De-Assert Level		-45			dBm	
Hysteresis		0.5		6	dBm	
Receiver Reflectance				-12	dBm	

XG PON Receiver Optical Characteristics

Table 8-XG PON Receiver Optical Characteristics

Parameter	Symbol	Min	Typical	Max	Unit	Notes
Operating Wavelength		1260		1280	nm	
Sensitivity	SEN			-29.5	dBm	ER≥6dB, PRBS2 ²³ @2 .488Gbps BER ≤1×10 ⁻⁴
Minimum Overload		-9			dBm	
Max Optical input				0	dBm	
SD Assert Level				-30.0	dBm	
SD De-Assert Level		-45			dBm	
Hysteresis		0.5		6	dB	
Receiver Reflectance				-12	dB	

XGS/XGPON Receiver Electrical Characteristics

Table 9-XGS/XGPON Receiver Electrical Characteristics

Parameter	Symbol	Min	Typical	Max	Unit	Notes
Guard time	T _g	50	100	-	ns	
Reset Pulse Width	Tr	25.6	-	-	ns	
Receiver Threshold Settling Time	T _{SETTLING}			100	ns	Figure 3
Data Output Differential Swing		400		800	mV	DC Coupled, CML output
Output Differential Impedance	Z _{out}	90	100	110	Ω	
SD Assert Level Time				100	ns	
SD De-Assert Level Time				100	ns	
SD Voltage - Low		0		0.4	V	
SD Voltage - High		2.4		VCC+0.3	V	

GPON Receiver Optical Characteristics

Table 10-GPON Receiver Optical Characteristics

Parameter	Symbol	Min	Typical	Max	Unit	Notes
Operating Wavelength		1290	1310	1330	nm	
Sensitivity	SEN			-32.0	dBm	ER≥10dB PRBS 2 ²³ @1.244Gbps BER ≤1×10 ⁻¹⁰
Minimum Overload		-12			dBm	
Max Optical input				0	dBm	
SD Assert Level				-32.5	dBm	
SD De-Assert Level		-45			dBm	
Hysteresis		0.5		6	dB	
CID		72			bit	

GPON Receiver Electrical Characteristics

Table 11-GPON Receiver Electrical Characteristics

Parameter	Symbol	Min	Typical	Max	Unit	Notes
Guard time	Tg	25.6	50	-	ns	
Reset Pulse Width	Tr	12.8	-	-	ns	
Receiver Threshold Settling Time	TSETTLE		25.6		ns	Figure 5
Data Output Differential Swing		600		1600	mV	LVPECL output, DC coupled
Output Differential Impedance	Zout	90	100	110	Ω	
SD Assert Level Time	Ta			24	ns	Figure 5
SD De-Assert Level Time				25.6	ns	
SD Voltage - Low		0		0.4	V	
SD Voltage - High		2.4		VCC+0.3	V	

Timing Parameter Definitions In Burst Mode Sequence

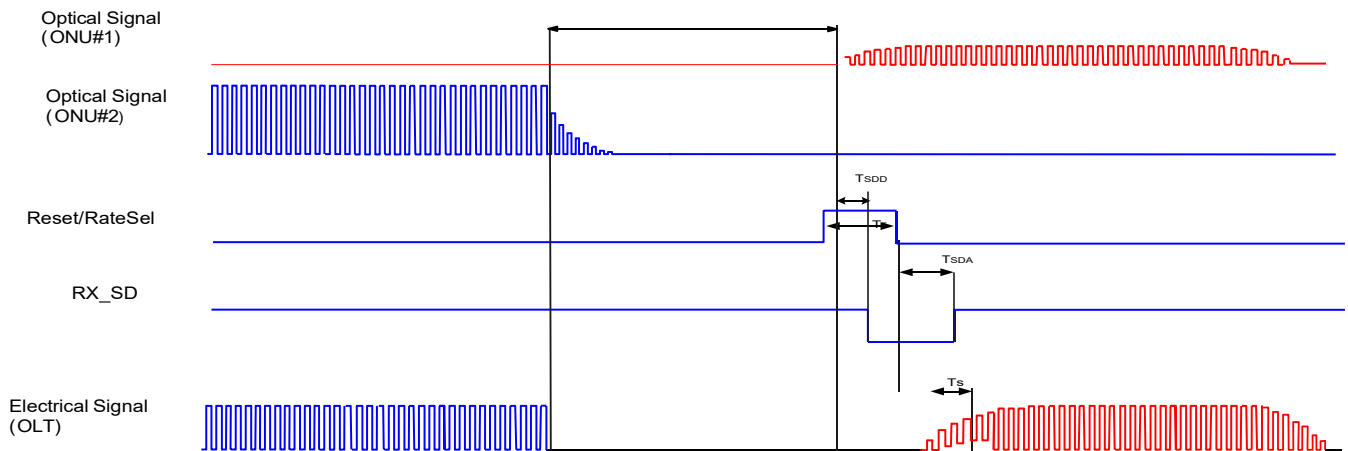

Figure 3 Timing Parameter Definitions in XGS PON Burst Mode Sequence

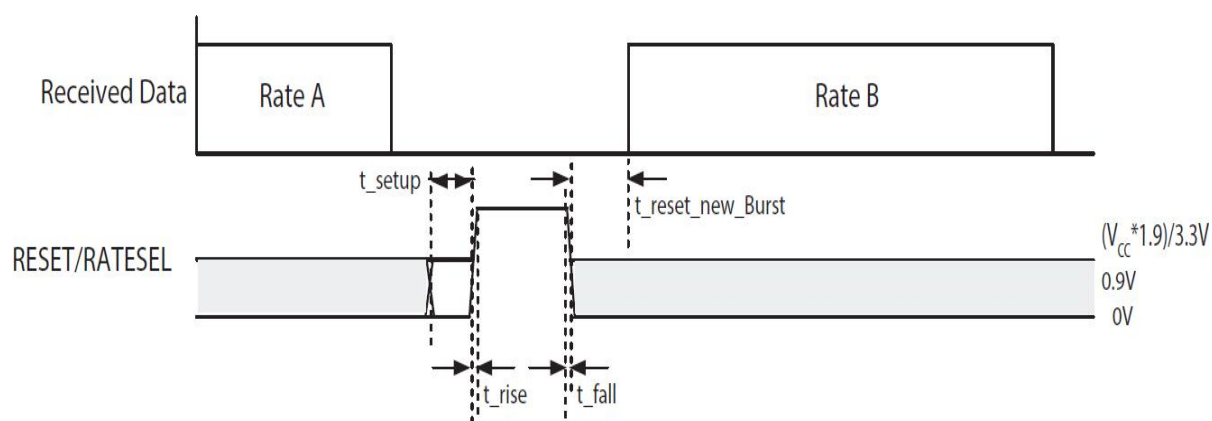

Figure 4 Reset/RateSel Timing Diagram

Reset/RateSel Function		
Reset/Ratesel	Voltage V	Function
High	1.9~3.3V	Reset
Middle	1.2~1.6V	Rate=2.488G
Low	0~0.9V	Rate=9.953G

Reset/RateSel Timing Diagram

Table 12 - Reset/RateSel Timing Diagram

Parameter	Symbol	Min	Typical	Max	Unit	Notes
Setup Time	TSetup	5			ns	
Reset Rise Time	TRise			3	ns	
Reset Fall Time	T fall			3	ns	
Reset New Burst Time	TReset new burst			0	ns	

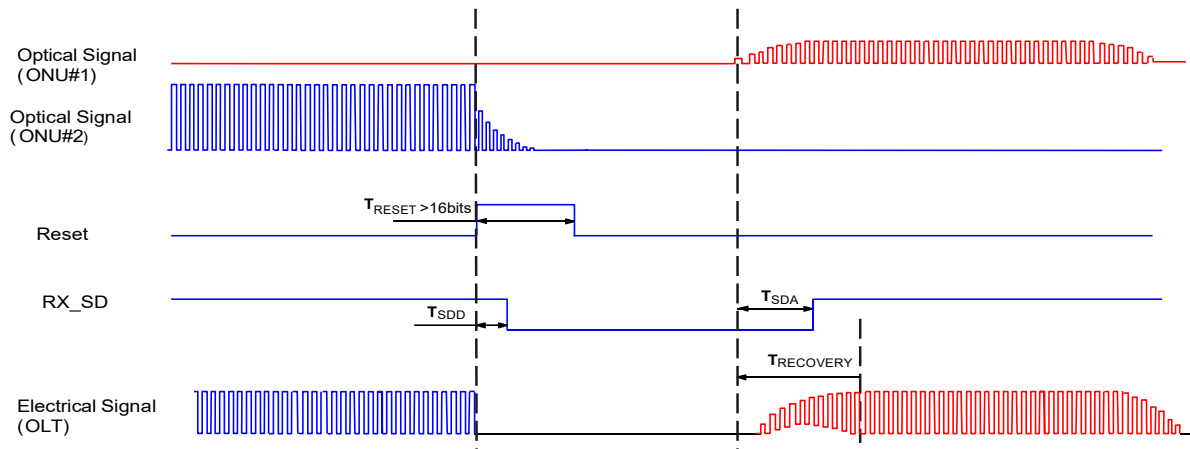

Figure 5 Timing Parameter Definitions in GPON Burst Mode Sequence

RSSI Timing Sequence

Table 13-RSSI Timing Sequence

Parameter	Symbol	Min	Typical	Max	Unit	Notes
Optical Signal Duration time	T_{opt}	1200			ns	
RSSI Trigger width	T_W	550			ns	
RSSI Trigger Delay	T_D	150			ns	
RSSI Trigger-Low		0		0.8	V	
RSSI Trigger-High		2.0		V_{cc}	V	
I ² C Access Prohibited Time	T_S	500			μs	
I ² C Bus Frequency		0	100	200	KHz	
I ² C - High		2.4		3.6	V	
I ² C - Low		0		0.4	V	

Digital RSSI Sample/Hold Timing Specification

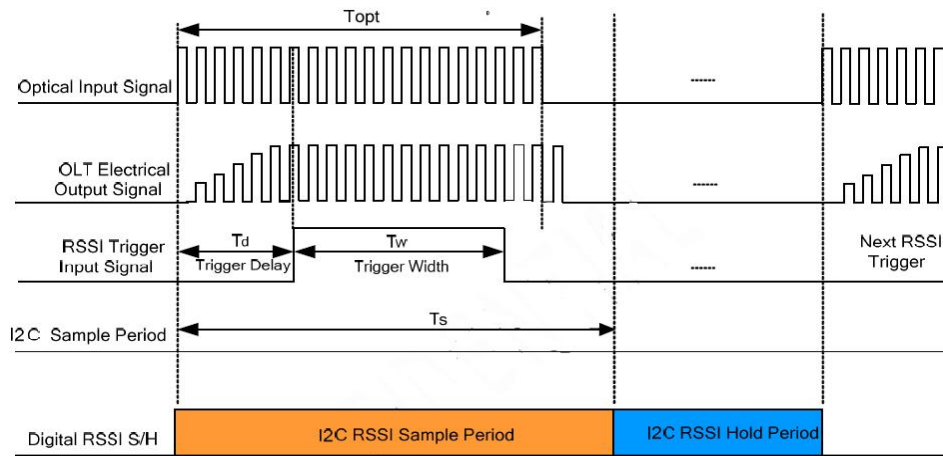
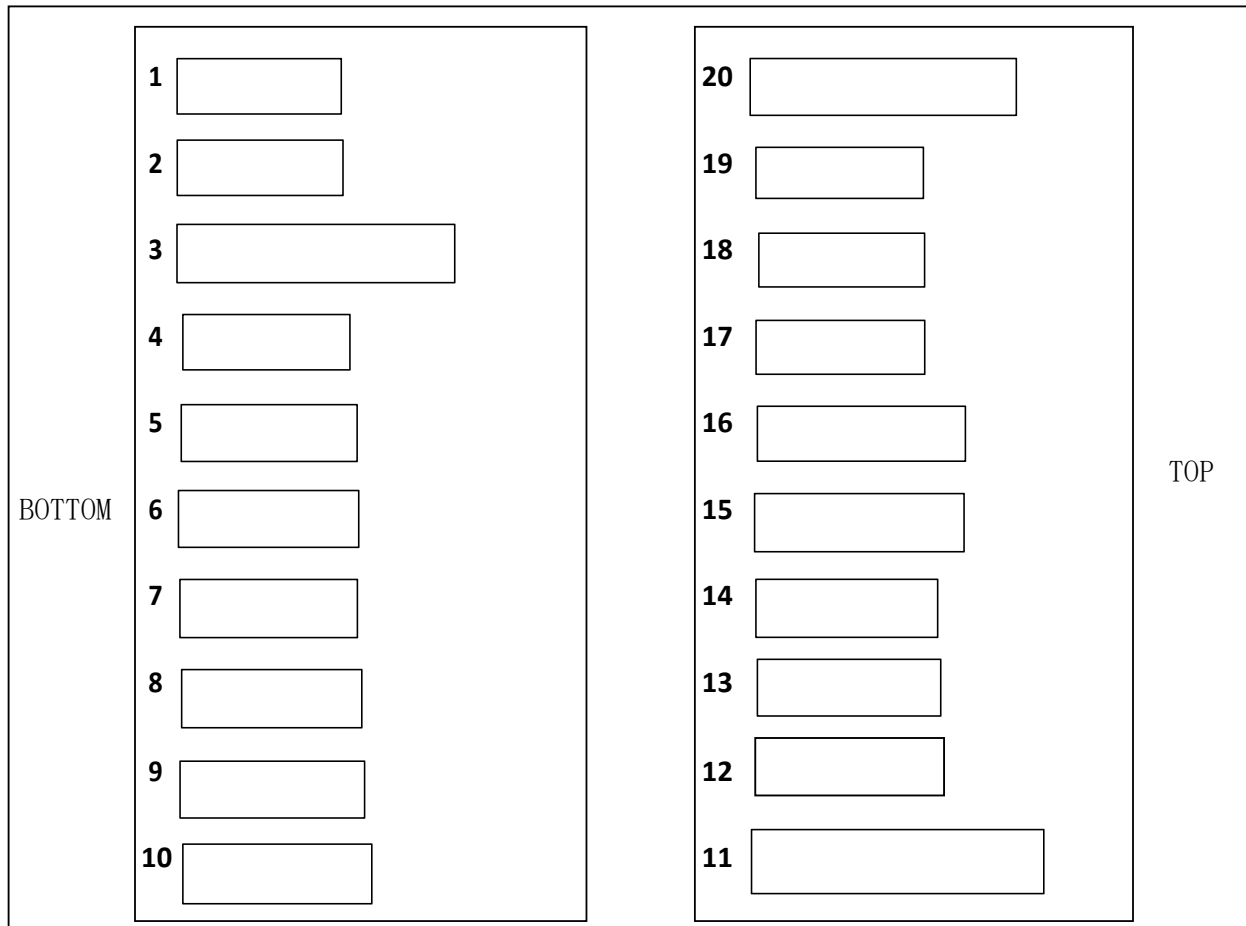

Figure 6 Timing Parameter Definitions in RSSI Trigger

Pin Out Drawing



Pin Descriptions

Table 14-Pin Descriptions

Pin	Name	Description	Notes
1	GPON_TD+	2.5G Transmit Data In	AC coupled, CML input
2	GPON_TD-	Inv. 2.5G Transmit Data In	AC coupled, CML input
3	GND	Module Ground	
4	SDA	2-Wire Serial Interface Data	The data line of two wire serial interface
5	SCL	2-Wire Serial Interface Clock	The clock line of two wire serial interface
6	GPON_RD-	Inv. Received 1G Data Out	DC coupled, LVPECL output ^[1]
7	Reset& Rate Select	XGSPON Reset& Rate Select	High: Reset, Middle:2.5G, Low:10G ^[2]
8	XGSPON SD	XSGPON SD Indicator	LOW: lost signal
9	Trig/Tx_Dis	Receiver RSSI trigger input /Transmitter Disable	The Mode can be switched ^[3]
10	GPON_RD+	Received 1G Data Out	DC coupled, LVPECL output ^[1]
11	GND	Module Ground	
12	XGSPON_RD-	Inv. Received 10G Data Out	DC coupled, CML output ^[5]
13	XGSPON_RD+	Received 10G Data Out	DC coupled, CML output ^[5]
14	GPON SD	GPON SD Indicator	
15	VCCR	3.3V DC Power Input	
16	VCCT	3.3V DC Power Input	
17	GPON RESET	GPON RESET	
18	XGSPON_TD+	differential 10G Transmit Data In	AC coupled, CML input
19	XGSPON_TD-	Inv. differential 10G Transmit Data In	AC coupled, CML input
20	GND	Module Ground	

Note 1: This contact shall be pulled down with LVPECL output in the host;

Note 2: High voltage is greater than 1.9V, intermediate voltage is 1.2V ~ 1.6V, low voltage is lower than 0.9V;

Note 3: A2 RSSI/TXDIS SELECTION

Address	Bit	Name	Description
A2 BYTE118	7	RSSI Select	Writing "0" for XGS-PON RSSI Monitor; Writing "1" for GPON RSSI Monitor. Default power up value is "0".
	6	RSSI/ TXDIS Select	When set "0", PIN9 input as TXDIS input; When set "1", PIN9 as RSSI input. Default power up value is "0".
	5	XGSPON TXDIS Selection	When set "0", PIN9 as the XGS-PON TXDIS input. Default power-up value: "0". [4].
	4	GPON TXDIS Selection	When set "0", PIN9 as the GPON TXDIS input. Default power-up value: "0". [4].

Note 4: The value is not "0", which represents keep the previous status.

Note 5: While XGS SD is low level, squelch function makes XGS LA output muting;

Package Outline

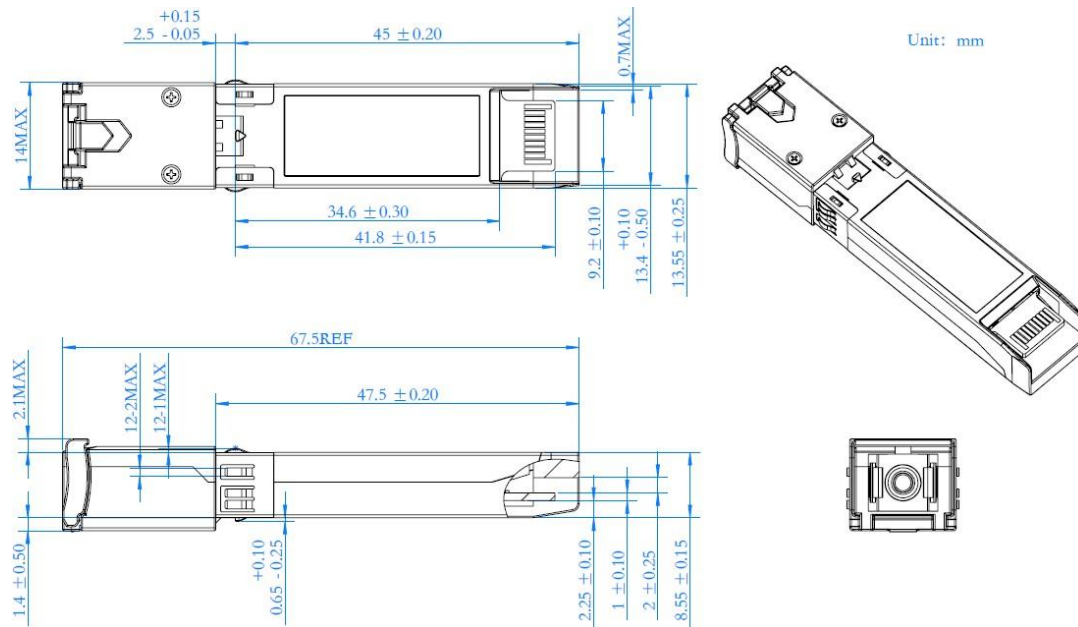

Figure 8 Package Outline

EEPROM Information

A0h(101000X) and B0h(1011000X) are the Serial ID addresses for XGSPON/XGPON and GPON OLT, respectively.

A2h(1010001X) and B2h(1011001X) are the Digital Diagnostic addresses for XGSPON/XGPON and GPON OLT, respectively.

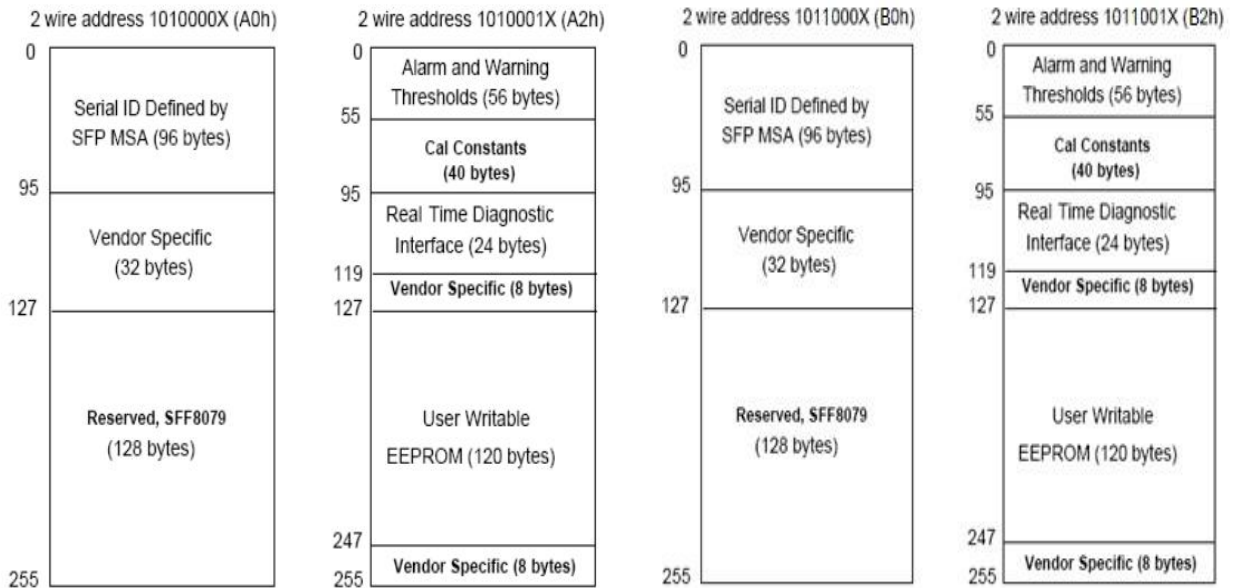

Figure 10 EEPROM Memory Map Specific Data Field Descriptions

XGS Digital Diagnostic Monitoring Interface

Table 15-XGS Digital Diagnostic Monitoring Interface

Parameter	Range	Accuracy	Calibration	Page	Address	Notes
Temperature	0 to 70°C	±3°C	Internal	A2	Byte 96~97, Byte96 is MSB	LSB: 1/256C
Voltage	2.97 to 3.63V	±5%	Internal	A2	Byte 98~99, Byte98 is MSB	LSB: 0.1mV
XGS-PON Bias Current	0 to 262mA	±10%	Internal	A2	Byte 100~101, Byte100 is MSB	LSB: 4uA
XGS-PON TX Power	4 to 7dBm	±2dB	Internal	A2	Byte 102~103, Byte102 is MSB	LSB: 0.2uW
XGS-PON RX Power Monitor	-30 to -7dBm	±3dB	Internal	A2	Byte 104~105, Byte104 is MSB	LSB: 0.1uW

GPON Digital Diagnostic Monitoring Interface

Table 16-GPON Digital Diagnostic Monitoring Interface

Parameter	Range	Accuracy	Calibration	Page	Address	Notes
Temperature	0 to 70°C	±3°C	Internal	B2	Byte 96~97, Byte96 is MSB	LSB: 1/256C
Voltage	2.97 to 3.63V	±5%	Internal	B2	Byte 98~99, Byte98 is MSB	LSB: 0.1mV
GPON Bias Current	0 to 262mA	±10%	Internal	B2	Byte 100~101, Byte100 is MSB	LSB: 4uA
GPON TX Power	3 to 7dBm	±2dB	Internal	B2	Byte 102~103, Byte102 is MSB	LSB: 0.2uW
GPON RX Power Monitor	-32 to -12dBm	±3dB	Internal	B2	Byte 104~105, Byte104 is MSB	LSB: 0.1uW

Ordering information

Table 17- Ordering information

Part Number	Product Description
XSPC-P9T9R-CN2C(I)	XGSPON&GPON Combo OLT SFP+ N2/C+, SC, C+/N2, 0 ~ +70°C, with DDM

AscentOptics reserves the right to make changes to the product(s) or information contained herein without notice. No liability is assumed as a result of their use or application. No rights under any patent accompany the sale of any such product(s) or information. Edition: Apr. 2019 Published by Ascent Optics Co.,Ltd. Copyright © Ascent Optics All Rights Reserved.

E-mail: sales@ascentoptics.com

Web : <http://www.ascentoptics.com>