

## XSPT-X9T9R-N1C(I)

XGSPON N1 PON XFP Transceiver

### Features

- Single fiber bi-directional data links TX 9.953Gbps, Burst Mode RX 9.953G/2.488Gbps application
- 0 to 70°C operating case temperature
- 3.3V power supply
- XFP package with SC Receptacle connector
- Hot-pluggable capability
- High power 1577nm EML LD & High sensitivity 1270nm APD
- Support 20km transmission distance with SMF
- SD indication
- Low EMI and excellent ESD protection
- Digital diagnostic monitor interface
- RoHS6 compliance



### Applications

- XGS-PON XFP OLT N1

### Standards

- Complies with INF-8077i
- Complies with ITU G.987.2
- Complies with ITU G.9807.1
- Complies with FCC 47 CFR Part 15, Class B
- Complies with FDA 21 CFR 1040.10 and 1040.11

## Absolute Maximum Ratings

**Table 1 - Absolute Maximum Ratings**

Parameter	Symbol	Min	Max	Unit	Notes
Storage Ambient Temperature	TSTG	-40	85	°C	
Operating Case Temperature	Tc	0	70	°C	
Operating Humidity	OH	5	85	%	
VCC3 Power Supply Voltage	VCC3	-0.5	3.6	V	

## Recommended Operating Environment

**Table 2 - Recommended Operating Environment**

Parameter	Symbol	Min	Typical	Max	Unit	Notes
Operating Case Temperature	Tc	0		+70	°C	
VCC3 Power Supply Voltage	VCC3	3.13	3.3	3.47	V	
VCC3 Power Supply Current	ICC3		-	1000	mA	
Date Rate			9.953 2.488		Gbps Gbps	
Date Rate Drift		-100		+100	PPM	
PowerConsumption	P		-	3	W	

## Transmitter Optical Characteristics

**Table 3-Transmitter Optical Characteristics**

Parameter	Symbol	Min	Typical	Max	Unit	Notes
Optical Center Wavelength	$\lambda_C$	1575		1580	nm	
Optical Spectrum Width (-20dB)	$\Delta\lambda$	-	-	1	nm	
Side Mode Suppression Ratio	SMSR	30			dB	
Optical Waveform Diagram	Compliant with ITU G.987.2					Figure 1, Mask Margin>5%
Average Launch Optical Power (BOL)	AOP2	+2.5		+6	dBm	Launched into SMF
Average Launch Optical Power (EOL)		+2		+6	dBm	Launched into SMF
Power-OFF Transmitter Optical Power				-39	dBm	Launched into SMF
Extinction Ratio	ER	8.2			dB	PRBS2 <sup>31</sup> -1 @9.953Gbps
Total Jitter	TJ			0.39	UI	PRBS2 <sup>31</sup> -1 @9.953Gbps
RIN15OMA				-128	dB/Hz	
Transmitter Reflectance				-10	dB	
Transmitter and Dispersion Penalty	TDP			1	dB	Transmit on 20km SMF

## Transmitter Electrical Characteristics

**Table 4-Transmitter Electrical Characteristics**

Parameter	Symbol	Min	Typical	Max	Unit	Notes
Data Input Differential Swing		120		850	mV	CML input, AC coupled
Input Differential Impedance		90	100	110	$\Omega$	
Transmitter Enable Voltage - Low		0		0.8	V	
Transmitter Disable Voltage - High		2.0		V <sub>CC</sub>	V	

## Transmitter Eye Mask Definitions And Test Procedure

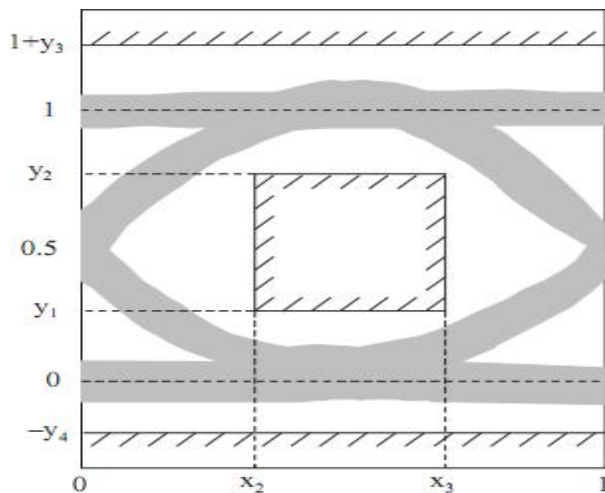

Figure 1 XGPON Transmitter Eye Mask Definitions

X3-X2	Y1	Y2	Y3	Y4	Unit
0.2	0.25	0.75	0.25	0.25	UI

## 10G PON Receiver Optical Characteristics

Table 5- Receiver Optical Characteristics

Parameter	Symbol	Min	Typical	Max	Unit	Notes
Operating Wavelength		1260		1280	nm	
Max Optical input				0	dBm	input without incurring damage
Sensitivity	SEN			-26	dBm	PRBS2 <sup>31</sup> -1@9.953Gbps BER ≤1×10 <sup>-3</sup>
Saturation Optical Power	SAT	-5			dBm	PRBS2 <sup>31</sup> -1@9.953Gbps BER ≤1×10 <sup>-3</sup>
SD Assert Level				-29	dBm	
SD De-assert Level		-45			dBm	
Hysteresis		0.5		6	dB	
Receiver Reflectance				-12	dB	

## 2.5G PON Receiver Optical Characteristics

Table 6-2.5GPON Receiver Optical Characteristics

Parameter	Symbol	Min	Typical	Max	Unit	Notes
Operating Wavelength		1260		1280	nm	
Max Optical input				0	dBm	input without incurring damage
Sensitivity	SEN			-27.5	dBm	PRBS 2 <sup>23</sup> -1@2.488Gbps BER ≤1×10 <sup>-4</sup>
Saturation Optical Power	SAT	-7			dBm	PRBS 2 <sup>23</sup> -1@2.488Gbps BER ≤1×10 <sup>-4</sup>
SD Assert Level				-29	dBm	
SD De-assert Level		-45			dBm	
Hysteresis		0.5		6	dB	
Receiver Reflectance				-20	dB	

## Timing Parameter Definitions In Burst Mode Sequence

Table 7-Timing Parameter Definitions In Burst Mode Sequence

Parameter	Symbol	Min	Typical	Max	Unit	Notes
RSSI Trigger-Low		0		0.8	V	
RSSI Trigger-High		2.0		V <sub>cc</sub>	V	
Data Output Differential Swing		340		850	mV	CML output, DC coupled
Reset-Low		0		0.8	V	
Reset-High		2.0		V <sub>cc</sub>	V	
SD Voltage-Low		0		0.4	V	
SD Voltage-High		2.4		V <sub>cc</sub>	V	
Reset Width	A	TBD			ns	

Reset to Valid Data Delay	B	TBD			ns	
SD De-assert Time	C			TBD	ns	
SD Assert Time	D			TBD	ns	
Data recovery time				TBD	ns	PRBS 2 <sup>23</sup> -1@2.488Gbps
				TBD	ns	PRBS 2 <sup>31</sup> -1@9.953Gbps

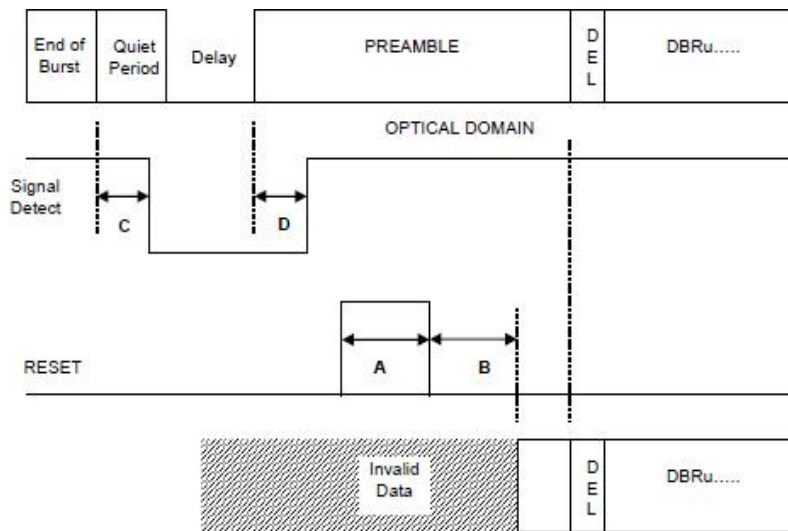

Figure 2 Reset Signal Timing Diagram in Normal Mode

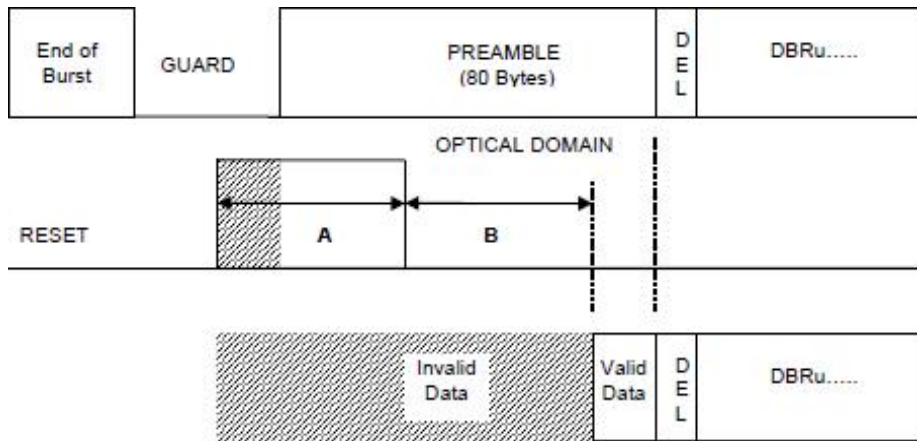

Figure 3 Reset Signal Timing Diagram in Ranging Mode

## RSSI Timing Sequence

Table 8-RSSI Timing Sequence

Parameter	Symbol	Min	Typical	Max	Unit	Notes
Optical Signal Duration time	$T_{ont}$	1200			ns	
RSSI Trigger width	$T_w$	550			ns	
RSSI Trigger Delay	$T_D$	150			ns	
I2C Access Prohibited Time		500			us	

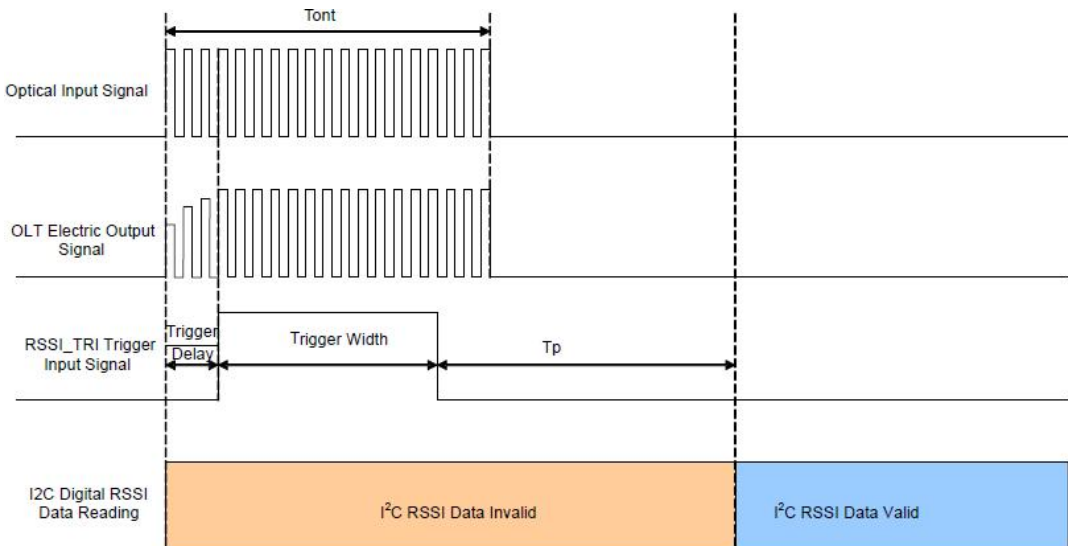

Figure 4 Timing Parameter Definitions in RSSI Trigger

## Pin Out Drawing

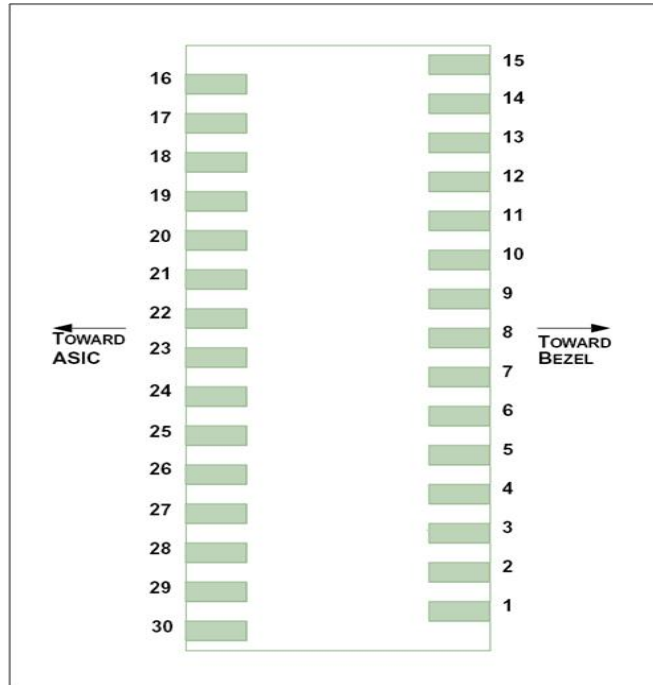

Figure 5 Pin Out Drawing

## Pin Descriptions

Table 9-Pin Descriptions

Pin	Name	Description	Notes
1	GND	Module Ground	
2	TX_FAULT	Transmitter Status Indication	Low : Normal; High: Abnormal
3	NC	Not Connected	
4	NC	Not Connected	
5	TX_DIS	Transmitter Disable	LVTTTL Input by 10k pull up resistor, Low : transmitter on
6	NC	Not Connected	
7	GND	Module Ground	



8	VCC3_TX	Transmitter 3.3V Power Supply	
9	VCC3_RX	Receiver 3.3V Power Supply	
10	SCL	The clock line	The clock line of two wire serial interface
11	SDA	The data line	The data line of two wire serial interface
12	MOD_ABS	Indicates Module is not present.	Grounded in the Module
13	RX_Reset	Burst Receiver Reset	LVTTTL, High level Reset
14	SD	SD Indication	LVTTTL output, active LOW when the receiver lost signal
15	GND	Module Ground	
16	GND	Module Ground	
17	RD_N	Inverted Received Data Out	CML output, DC coupled; No squelch function
18	RD_P	Non-inverted Received Data Out	CML output, DC coupled; No squelch function
19	GND	Module Ground	
20	NC	Not Connected	
21	RSSI_TRIG	RSSI Trigger for Transceiver	High value indicates start RSSI measurement
22	NC	Not Connected	
23	GND	Module Ground	
24	NC	Not Connected	
25	NC	Not Connected	
26	GND	Module Ground	
27	GND	Module Ground	
28	TX_N	Inverted Transmit Data in	CML input, AC coupled
29	TX_P	Non-Inverted Transmit Data in	CML input, AC coupled
30	GND	Module Ground	

## Typical Interface Circuit

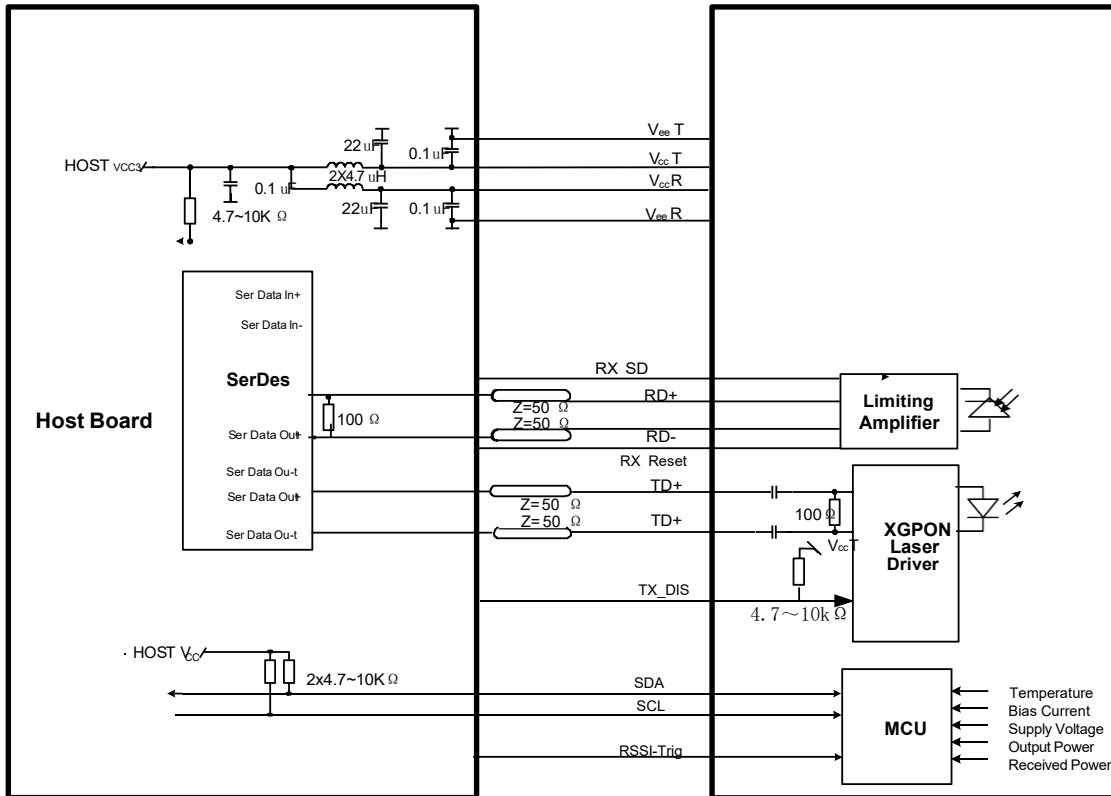

Figure 6 Typical Interface Circuit

## Package Outline

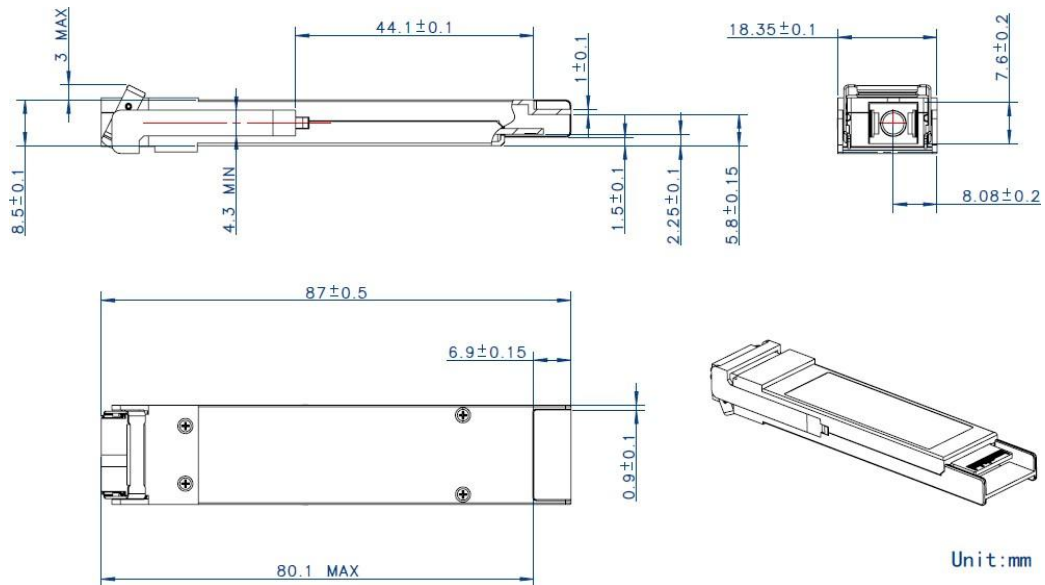

Figure 7 Package Outline

## EEPROM Information

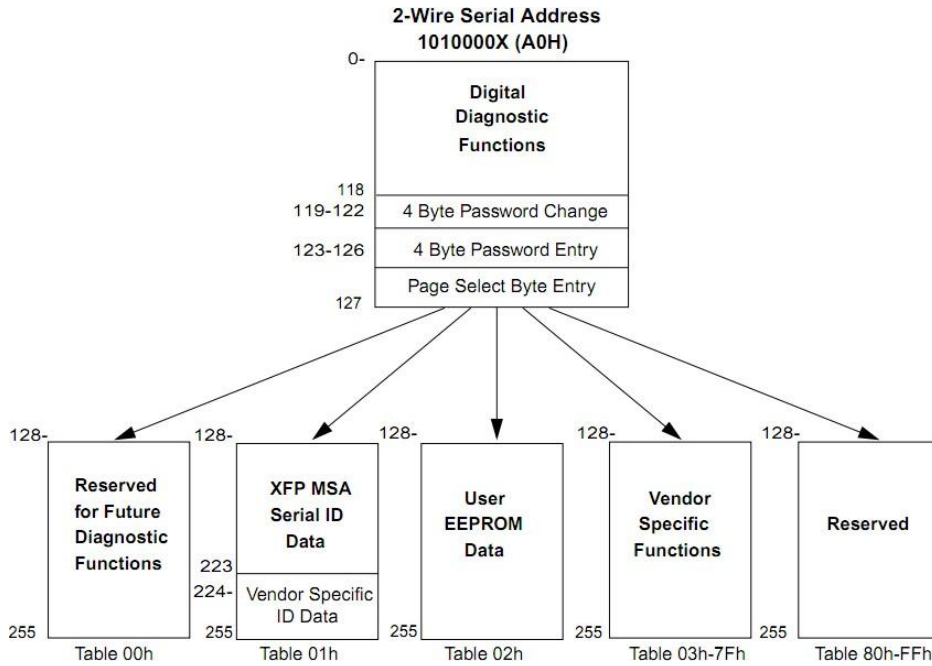

Figure 8 EEPROM Memory Map Specific Data Field Descriptions

## Digital Diagnostic Monitoring Interface

Table 10-Digital Diagnostic Monitoring Interface

Parameter	Range	Accuracy	Calibration	Notes
Temperature	0 to 70°C	±3°C	Internal	LSB: 1/256°C
Voltage	0 to 3.6V	±5%	Internal	LSB: 0.1mV
Bias Current	0 to 131mA	±10%	Internal	LSB: 4uA
TX Power	1 to 7dBm	±2dB	Internal	LSB: 0.2uW
RX Power	-29 to -6dBm	±3dB	Internal	LSB: 0.1uW

**Ordering information****Table 11- Ordering information**

Part Number	Product Description
XSPT-X9T9R-N1C(I)	XGSPON OLT XFP N1, SC, N1, 1577T/1270R, 0 ~ +70°C, with DDM

AscentOptics reserves the right to make changes to the product(s) or information contained herein without notice. No liability is assumed as a result of their use or application. No rights under any patent accompany the sale of any such product(s) or information. Edition: Apr. 2019 Published by Ascent Optics Co.,Ltd. Copyright © Ascent Optics All Rights Reserved.

E-mail: [sales@ascentoptics.com](mailto:sales@ascentoptics.com)

Web : <http://www.ascentoptics.com>