

GUF-0S12-20C

GPON ONU 1310nm/1490nm SFF Transceiver

Features

- BiDi SFF Single Mode Transceiver
- SC receptacle
- Comply with ITU-T G.984.5 Class B+
- Compliant with SFF MSA-2000 And SFF-8472 V10.3
- Single +3.3 Power Supply
- LVPECL Differential Data Inputs And CML Data Outputs
- LVTTTL Signal Detection Output And LVTTTL Burst Control
- Complies with Telecordia (Bellcore) GR-468-CORE
- 1310 nm Burst Mode Transmitter and 1490 nm Continuous Mode Receiver 1.244Gbps DFB Laser Diode, 2.488Gbps APD-TIA Receiver
- Maximal reach 20km



Applications

- GPON ONU For P2MP Application

General

The GUF-0S12-20C transceiver with SFF 2*10 package supports typically Tx 1.244Gbps and Rx 2.488Gbps Asymmetric Data Rate for GPON ONU application up to 20km transmission distance, it's designed meeting with ITU-T G.984.5 Class B+. SC receptacle is for optical interface.

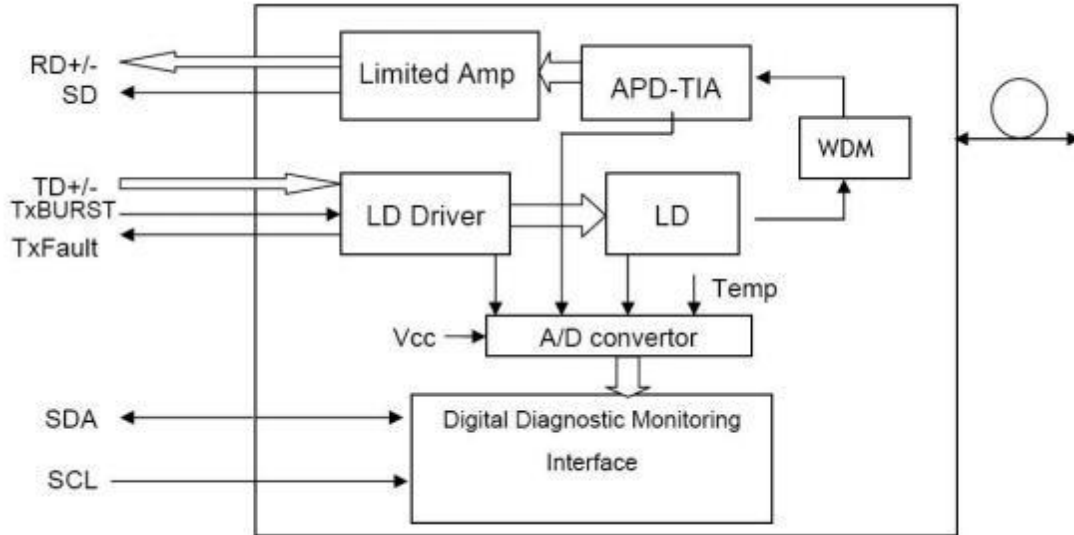

Fig 1 Transceiver Block Diagram

The module provides digital diagnostic information of its operating conditions and status, including transmitting power, laser bias, receiver input optical power, module temperature, and supply voltage. Calibration and alarm/warning threshold data are written and stored in internal memory (EEPROM). The memory map is compatible with SFF-8472, as shown in Fig. 2. The diagnostic data are raw A/D values and must be converted to real world units using calibration constants stored in EEPROM locations 56 – 95 in A2h.

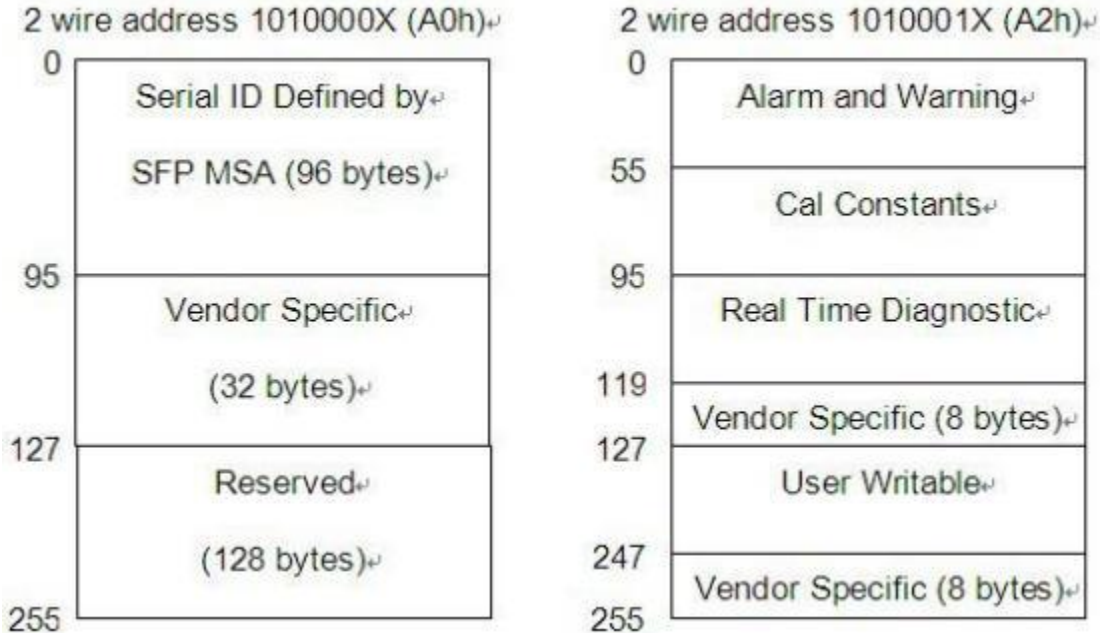

Fig 2 EEPROM Information

Absolute Maximum Ratings

Table 1- Absolute Maximum Ratings

Parameter	Symbol	Min.	Max.	Unit	Note
Storage Temperature	Tst	-40	+85	°C	
Operating Case Temperature	Tc	0	70	°C	GUF-0S12-20C
		-40	+85		GPON-ONT-SFF-I
Input Voltage	-	GND	Vcc	V	
Power Supply Voltage	Vcc-Vee	-0.5	+3.6	V	
Damage Threshold For Receiver	-	-	4	dBm	
Soldering Temperature / Time	-	-	260/ 10	°C/S	

Recommended Operating Conditions

Table 2- Recommended Operating Conditions

Parameter	Symbol	Min.	Typical	Max.	Unit	Note
Power Supply Voltage	Vcc	3.135	3.3	3.465	V	-
Operating Case Temperature	Tc	0	-	70	°C	GUF-0S12-20C
		-40	-	85		GPON-ONT-SFF-I
Total Supply Current	-	-	-	350	mA	-

Optical Specification

Table 3- Optical Specification

Transmitter							
Parameter	Symbol	Min.	Typ.	Max.	Unit	Note	
Data Rate	DR	-	1.244	-	Gbps	-	
Optical Central Wavelength	λ	1290	1310	1330	nm		
Spectral Width (-20dB)	$\Delta\lambda$	-	-	1	nm		
Side Mode Suppression Ratio	SMSR	30	-	-	dB		
Average Optical Output Power	Po	0.5	-	5	dBm		
Extinction Ratio	Er	10	-	-	dB	-	
Transmitter Reflectance	-	-	-	- 12	dB		
Tx Burst ON Time	Ton	-	-	12.8	ns	-	
Tx Burst OFF Time	Toff	-	-	12.8	ns	-	
Rise/Fall Time	Tr/Tf	-	-	250	ps	-	
Average Launched Power of Off Transmitter	Poff	-	-	-45	dBm	-	
Output Eye	Compliant with ITU-T G.984.5						
Receiver							
Parameter	Symbol	Min.	Typ.	Max.	Unit	Note	

Data Rate	DR	-	2.488	-	Gbps	-
Operate Wavelength	-	1480	-	1500	nm	-
Sensitivity	Pr	-	-	-28	dBm	1
Saturation	Ps	-8	-	-	dBm	1
SD De-assert Level	-	-45	-	-	dBm	-
SD Assert Level	-	-	-	-28	dBm	-
SD Hysteresis	-	0.5	-	6	dB	-
Receiver Reflectance	-	-	-	- 12	dB	-
RSSI Range	-	-28	-	-8	dBm	-
RSSI Accuracy	-	-3	-	+3	dB	-

Note:

1. Minimum Sensitivity and saturation levels for a $2^{23} - 1$ PRBS. $BER \leq 10^{-10}$, 2.488Gbps, ER=9dB

Electrical Specification

Table 4- Electrical Specification

Transmitter						
Parameter	Symbol	Min.	Typ.	Max.	Unit	Note
Differential Input Voltage	V IN-DIF	200	-	1600	V	-
Tx Burst Input Voltage-Low	V IL	0	-	0.8	V	-
Tx Burst Input Voltage-High	V IH	2.0	-	Vcc	V	-
Receiver						
Parameter	Symbol	Min.	Typ.	Max.	Unit	Note
Data Output Voltage Differential	V OUT-DIF	400	-	1000	V	-
Signal Detect Output Voltage-Low	V SD-L	0	-	0.8	V	-
Signal Detect Output Voltage-High	V SD-H	2.0	-	Vcc	V	-

EEPROM Information

Table 5-EEPROM Serial ID Memory Contents (A0h)

Addr. (decimal)	Field Size (Bytes)	Name of Field	Content (Hex)	Content (Decimal)	Description
0	1	Identifier	02	2	SFF
1	1	Ext. Identifier	04	4	MOD4
2	1	Connector	01	01	Receptacle
3- 10	8	Transceiver	00 00 00 00 00 00 00 00	00 00 00 00 00 00 00 00	Not defined

11	1	Encoding	03	3	NRZ
12	1	BR, nominal	0C	12	1.25Gbps
13	1	Reserved	00	0	-
14	1	Length (9um)-km	14	20	20km
15	1	Length (9um)	C8	200	20km
16	1	Length (50um)	00	0	-
17	1	Length (62.5um)	00	0	-
18	1	Length (copper)	00	0	-
19	1	Reserved	00	0	-
20-35	16	Vendor name	5A 4B 54 45 4C 20 20 20 20 20 20 20 20 20 20 20	90 75 84 69 76 32 32 32 32 32 32 32 32 32 32 32	'AscentOptics' (ASCII)
36	1	Reserved	00	0	-
37-39	3	Vendor OUI	00 00 00	0 0 0	-
40-55	16	Vendor PN	5A 50 34 33 34 32 30 33 34 2D 4B xx 53 xx 20 20	90 80 52 51 52 50 48 51 52 45 75 xx 83 xx 32 32	'GUF-0S12-20C' (ASCII)
56-59	4	Vendor rev	30 30 30 20	48 48 48 32	"000" (ASCII)
60-61	2	Wavelength	05 1E	05 30	1310
62	1	Reserved	00	0	-
63	1	CC BASE	-	-	Check sum of bytes 0 - 62
64	1	Reserved	00	0	
65	1	Options	1A	26	
66	1	BR, max	00	0	-
67	1	BR, min	00	0	-
68-83	16	Vendor SN	-	-	ASCII
84-91	8	Vendor date	-	-	Year (2 bytes), Month (2 bytes), Day (2 bytes)
92	1	DDM Type	58/68	88/ 104	External/ Internal Calibrated
93	1	Enhanced Option	B0	176	LOS, TX_FAULT and Alarm/ warning flags implemented
94	1	SFF-8472 Compliance	03	3	SFF-8472 Rev 10.3
95	1	CC EXT	-	-	Check sum of bytes 64 - 94

96-255	160	Vendor spec			
--------	-----	-------------	--	--	--

Table 6-Alarm and Warning Thresholds (Serial ID A2H)

Parameter(Unit)	C Temp (C)	I Temp (C)	Voltage (V)	Bias (mA)	TX Power (dBm)	RX Power (dBm)
High Alarm	100	100	3.6	90	5	-8
Low Alarm	-10	-40	3	0	0.5	-28
High Warning	95	95	3.5	70	4	-9
Low Warning	0	-30	3.1	0	1	-27

Digital Diagnostic Monitor Accuracy

Table 7- Digital Diagnostic Monitor Accuracy

Parameter	Unit	Accuracy	Range	Calibration
Tx Optical Power	dB	±3	Po: -Pomin~Pomax dBm , Recommended operation conditions	External/ Internal
Rx Optical Power	dB	±3	Pi: Ps~Pr dBm , Recommended operation conditions	External/ Internal
Bias Current	%	±10	Id: 1- 100mA, Recommended operating conditions	External/ Internal
Power Supply Voltage	%	±3	Recommended operating conditions	External/ Internal
Internal Temperature	C	±3	Recommended operating conditions	External/ Internal

PIN Diagram

PIN	FUNCTION	PIN	FUNCTION
1	NC	11	VCCT
2	NC	12	VEER
3	NC	13	Tx_Burst
4	NC	14	TX_DATA+
5	NC	15	TX_DATA-
6	VEER	16	VEET
7	VCCR	17	SCL
8	SD	18	SDA
9	Rx_DATA-	19	TX_FAULT
10	Rx_DATA+	20	TX_SD(OPT)

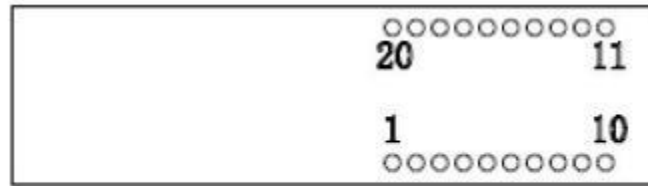

TOP VIEW

PIN Description

Pin No.	Name	Description
1	NC	
2	NC	
3	NC	
4	NC	
5	NC	
6	VEER	Receiver Ground
7	VCCR	Receiver Power Supply
8	SD	Signal Detect Output. H--Normal Operation; L--Los Of Signal
9	_Rx DATA-	Receiver Data Output Negative
10	_Rx DATA+	Receiver Data Output Positive
11	VCCT	Transmitter Power Supply
12	VEET	Transmitter Ground
13	TX BURST _	Transmitter Burst Mode Control. Burst Logic '1' or Logic '0' Tx on pleaser refer to order information
14	_TX DATA+	Transmitter Data Input Positive
15	TX DATA- _	Transmitter Data Input Negative
16	VEET	Transmitter Ground
17	SCL	I2C Serial Clock
18	SDA	I2C Serial Data
19	TX FAULT	Transmitter Fault
20	Tx SD	Tx Transmitter State Indication, assert When Tx ON .Optional

Recommended Circuit

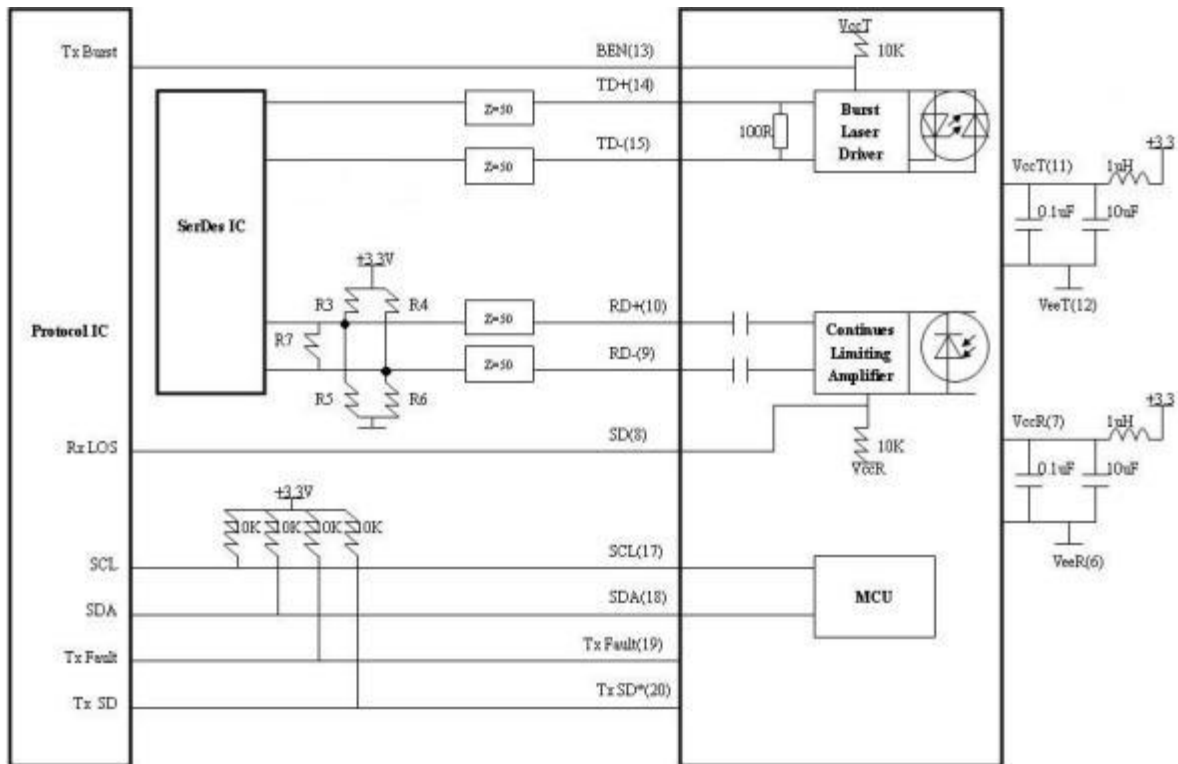

Note:

Tx: DC coupled internally.

Rx: AC coupled internally.

Input stage in SerDes IC with internal bias to Vcc- 1.3V

R3=R4=R5=R6=N.C, R7=100Ω

Input stage in SerDes IC without internal bias to Vcc- 1.3V R3=R4=82Ω,R5=R6=130Ω,R7=N.C

Burst Mode Sequence Definition

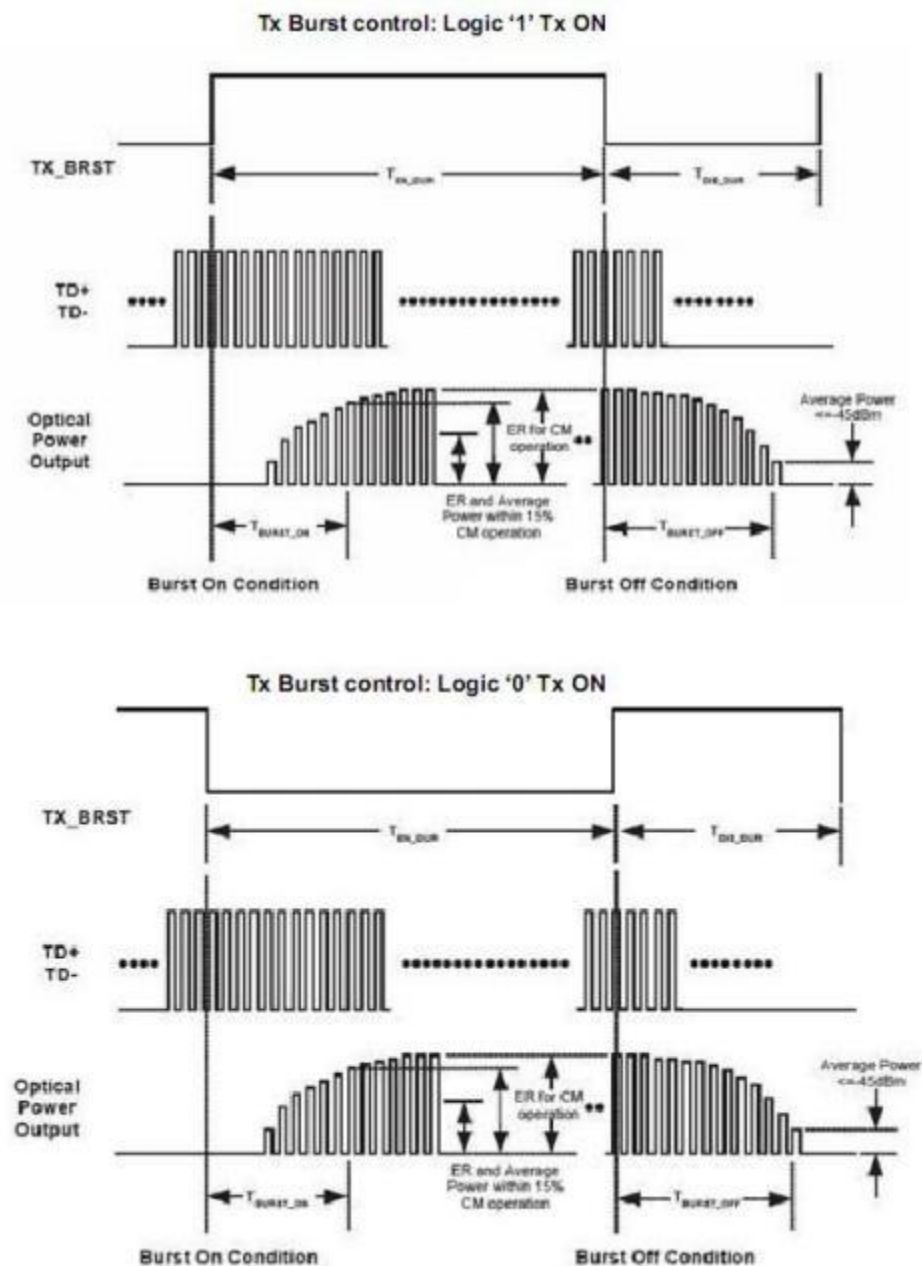

Package Diagram

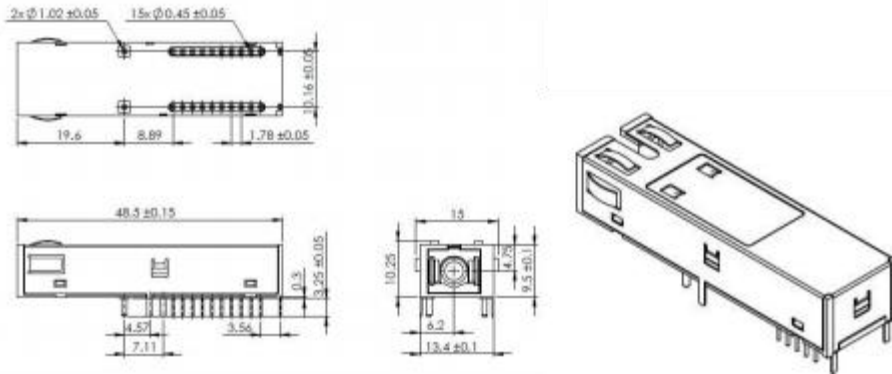

Order Information

Part Number	Description
GUF-0S12-20C	TX 1.25G/RX 2.5G GPON ONT/ONU Tx 1310nm/ Rx1490nm 2x10 SFF 20km SC DDM,0-70°C,

AscentOptics reserves the right to make changes to the product(s) or information contained herein without notice. No liability is assumed as a result of their use or application. No rights under any patent accompany the sale of any such product(s) or information. Edition: Apr. 2019 Published by Ascent Optics Co.,Ltd. Copyright © Ascent Optics All Rights Reserved.

E-mail: sales@ascentoptics.com
Web : <http://www.ascentoptics.com>