

---

## EUF-0P11-20C

### SFF EPON 1000BASE-PX20+ ONU Transceiver

#### Features

- BiDi SFF Single Mode Transceiver
- SC/PC or SC/APC Pigtail is optional
- Compliant with SFF MSA-2000 And SFF-8472 V10.3
- Single +3.3 Power Supply
- LVPECL Differential Inputs and Outputs And LVTTTL Signal Detection Output
- Complies with Telcordia (Bell core) GR-468-CORE
- 1310 nm Burst Mode Transmitter and 1490 nm Continuous Mode Receiver
- Typical data rate 1.25 Gbps
- Maximal reach 20km
- Comply with 1000Base-PX20+



#### Applications

- GEAPON ONU For P2MP Application

#### General

The EUF-0P11-20C transceiver with SFF 2\*10 package supports data rate of typical 1.25 Gbps for GEAPON ONU application up to 20km transmission distance, it's designed meeting with 802.3 ah and China Telecom 1000BASE-PX20+ specifications. SC/PC pigtail or SC/APC pigtail is for optical interface.

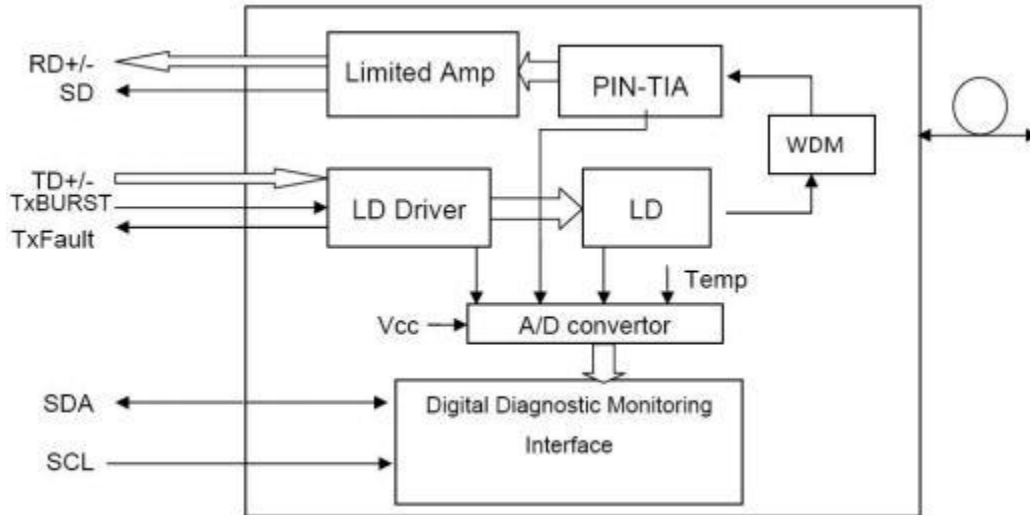

The module provides digital diagnostic information of its operating conditions and status, including transmitting power, laser bias, receiver input optical power, module temperature, and supply voltage. Calibration and alarm/warning threshold data are written and stored in internal memory (EEPROM). The memory map is compatible with SFF-8472, as shown in The diagnostic data are raw A/D values and must be converted to real world units using calibration constants stored in EEPROM locations 56 – 95 in A2h.

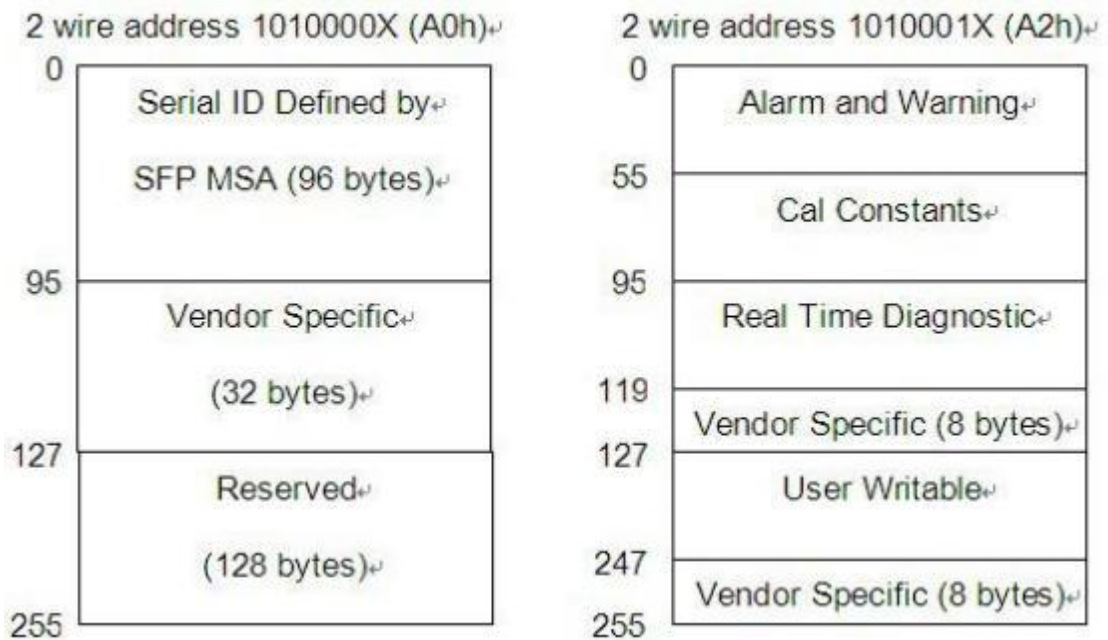

## Absolute Maximum Ratings

**Table 1- Absolute Maximum Ratings**

Parameter	Symbol	Min.	Max.	Unit	Note
Storage Temperature	Tst	-40	+85	°C	
Operating Case Temperature	Tc	0	70	°C	EPON-ONT-SFPP-C
		-40	+85		EPON-ONT-SFPP-I
Input Voltage	-	GND	Vcc	V	
Power Supply Voltage	Vcc-Vee	-0.5	+3.6	V	

## Recommended Operating Conditions

**Table 2- Recommended Operating Conditions**

Parameter	Symbol	Min.	Typical	Max.	Unit	Note
Power Supply Voltage	Vcc	3.135	3.3	3.465	V	-
Operating Temperature	Tc	0	-	70	°C	EPON-ONT-SFPP-C
		-40	-	85		EPON-ONT-SFPP-I
Data Rate	DR	-	1.25	-	Gbps	-
Total Supply Current	-	-	200	300	mA	-
Damage Threshold For Receiver	-	-	-	4	dBm	-

## Optical Specification

**Table 3- Optical Specification**

Transmitter						
Parameter	Symbol	Min.	Typ.	Max.	Unit	Note
Optical Central Wavelength	$\lambda$	1260	1310	1360	nm	
Spectral Width (RMS)	1260nm	-	-	0.72		
	1270nm	-	-	0.86		
	1280nm	-	-	1.07		
	1290nm	-	-	1.4		

	1300nm	$\Delta\lambda$	-	-	2.0	nm	
	1304nm		-	-	2.5		
	1305nm		-	-	2.55		
	1308nm		-	-	3.0		
	1317nm		-	-	2.53		
	1320nm		-	-	2.41		
	1321nm		-	-	1.71		
	1330nm		-	-	1.29		
	1340nm		-	-	1.05		
	1350nm		-	-	0.88		
	1360nm		-	-			
Average Optical Output Power		Po	0	-	4	dBm	
Extinction Ratio		Er	9	-	-	dB	-
Tx Burst ON Time		Ton	-	-	50	ns	-
Tx Burst OFF Time		Toff	-	-	50	ns	-
Rise/Fall Time		Tr/Tf	-	-	260	ps	-
Transmitter Total Jitter		Jp-p	-	-	280	ps	
Average Launched Power of		Poff	-	-	-45	dBm	-
Output Eye		Compliant with IEEE 802.3ah-2004					
Receiver							
Parameter	Symbol	Min.	Typ.	Max.	Unit	Note	
Operate Wavelength	-	1480	-	1500	nm	-	
Sensitivity	Pr	-	-	-27	dBm	1	
Saturation	Ps	-3	-	-	dBm	1	
SD De-assert Level	-	-44	-	-	dBm	-	
SD Assert Level	-	-	-	-27	dBm	-	
SD Hysteresis	-	0.5	-	5	dB	-	
Optical Reflectance	-	-	-	-12	dB	-	
Optical Isolation from the external source	ISO1	38	-	-	dB	$\lambda=1550\text{nm}$	
	ISO2	35	-	-	dB	$\lambda=1650\text{nm}$	

## Electrical Specification

**Table 4- Electrical Specification**

Transmitter						
Parameter	Symbol	Min.	Typ.	Max.	Unit	Note
Differential Input Voltage	V IN-DIF	300	-	1600	m V	-
Tx Burst Input Voltage-Low	V IL	0	-	0.8	V	-
Tx Burst Input Voltage-High	V IH	2.0	-	Vcc	V	-
Receiver						
Parameter	Symbol	Min.	Typ.	Max.	Unit	Note
Data Output Voltage Differential	V OUT-DIF	300	-	1600	V	-
Signal Detect Output Voltage-Low	V SD-L	0	-	0.8	V	-
Signal Detect Output Voltage-High	V SD-H	2.0	-	Vcc	V	-

## EEPROM Information

**Table 5-EEPROM Serial ID Memory Contents (A0h)**

Addr. (decimal)	Field Size (Bytes)	Name of Field	Content (Hex)	Content (Decimal)	Description
0	1	Identifier	02	2	SFF
1	1	Ext. Identifier	04	4	MOD4
2	1	Connector	0B	11	Optical Pigtail
3-10	8	Transceiver	00 00 00 80 00 00 00 00	00 00 00 80 00 00 00 00	Transmitter Code
11	1	Encoding	01	1	8B10B
12	1	BR, nominal	0C	12	1.25Gbps
13	1	Reserved	00	0	-
14	1	Length (9um)-km	14	20	20km
15	1	Length (9um)	C8	200	20km
16	1	Length (50um)	00	0	-
17	1	Length (62.5um)	00	0	-
18	1	Length (copper)	00	0	-

19	1	Reserved	00	0	-
20-35	16	Vendor name	5A 4B 54 45 4C 20 20 20 20 20 20 20 20 20 20 20	90 75 84 69 76 32 32 32 32 32 32 32 32 32 32 32	'AscentOptics' (ASCII)
36	1	Reserved	00	0	-
37-39	3	Vendor OUI	00 00 00	0 0 0	-
40-55	16	Vendor PN	5A 50 34 33 34 32 30 33 33 2D 48 xx xx xx 20 20	90 80 52 51 52 50 48 51 51 45 72 xx xx xx 32 32	'EPON-ONT-S FPP-C (ASCII)
56-59	4	Vendor rev	30 30 30 20	48 48 48 32	"000" (ASCII)
60-61	2	Wavelength	05 1E	05 30	1310
62	1	Reserved	00	0	-
63	1	CC BASE	-	-	Check sum of bytes 0 - 62
64	1	Reserved	00	0	
65	1	Options	1A	26	
66	1	BR, max	00	0	-
67	1	BR, min	00	0	-
68-83	16	Vendor SN	-	-	ASCII
84-91	8	Vendor date	-	-	Year (2 bytes), Month (2 bytes), Day (2 bytes)
92	1	DDM Type	58/68	88/104	External/ Internal Calibrated
93	1	Enhanced Option	B0	176	LOS, TX_FAULT

					and Alarm/ warning flags implemented
94	1	SFF-8472 Compliance	03	3	SFF-8472 10.3
95	1	CC EXT	-	-	Check sum of bytes 64 - 94
96-255	160	Vendor spec			

R  
e  
v

**Table 6-Alarm and Warning Thresholds (Serial ID A2H)**

Parameter(Unit)	CTemp (C)	I Temp( C)	Voltage (V)	Bias (mA)	TX Power (dBm)	RX Power (dBm)
High Alarm	100	100	3.6	90	4	-3
Low Alarm	- 10	-40	3	0	0	-27
High Warning	95	95	3.5	70	3	-4
Low Warning	0	-30	3.1	0	1	-26

## Digital Diagnostic Monitor Accuracy

**Table 7- Digital Diagnostic Monitor Accuracy**

Parameter	Unit	Accuracy	Range	Calibration
Tx Optical Power	dB	±3	Po: -Pomin~Pomax dBm , Recommended operation conditions	External/ Internal
Rx Optical Power	dB	±3	Pi: Ps~Pr dBm, Recommended operation conditions	External/ Internal
Bias Current	%	±10	Id: 1- 100mA, Recommended operating conditions	External/ Internal

Power Supply Voltage	%	$\pm 3$	Recommended operating conditions	External/ Internal
Internal Temperature	C	$\pm 3$	Recommended operating conditions	External/ Internal

## PIN Diagram

PIN	FUNCTION	PIN	FUNCTION
1	NC	11	VCCT
2	NC	12	VEER
3	NC	13	Tx_Burst
4	NC	14	TX_DATA+
5	NC	15	TX_DATA-
6	VEER	16	VEET
7	VCCR	17	SCL
8	SD	18	SDA
9	Rx_DATA-	19	TX_FAULT
10	Rx_DATA+	20	TX_SD(OPT)



TOP VIEW

## PIN Description

Table 8- PIN Description

Pin No.	Name	Description
1	NC	
2	NC	
3	NC	
4	NC	
5	NC	
6	VEER	Receiver Ground



7	VCCR	Receiver Power Supply
8	SD	Signal Detect Output. H--Normal Operation; L--Los Of Signal
9	Rx_ DATA-	Receiver Data Output Negative
10	Rx_ DATA+	Receiver Data Output Positive
11	VCCT	Transmitter Power Supply
12	VEET	Transmitter Ground
13	TX_ BURST	Transmitter Burst Mode Control. Burst Logic '1' or Logic '0' Tx on pleaser refer to order information
14	TX_ DATA+	Transmitter Data Input Positive
15	TX_ DATA-	Transmitter Data Input Negative
16	VEET	Transmitter Ground
17	SCL	I2C Serial Clock
18	SDA	I2C Serial Data
19	TX FAULT	Transmitter Fault
20	Tx SD	Tx Transmitter State Indication, assert When Tx ON .Optional

## Recommended Circuit

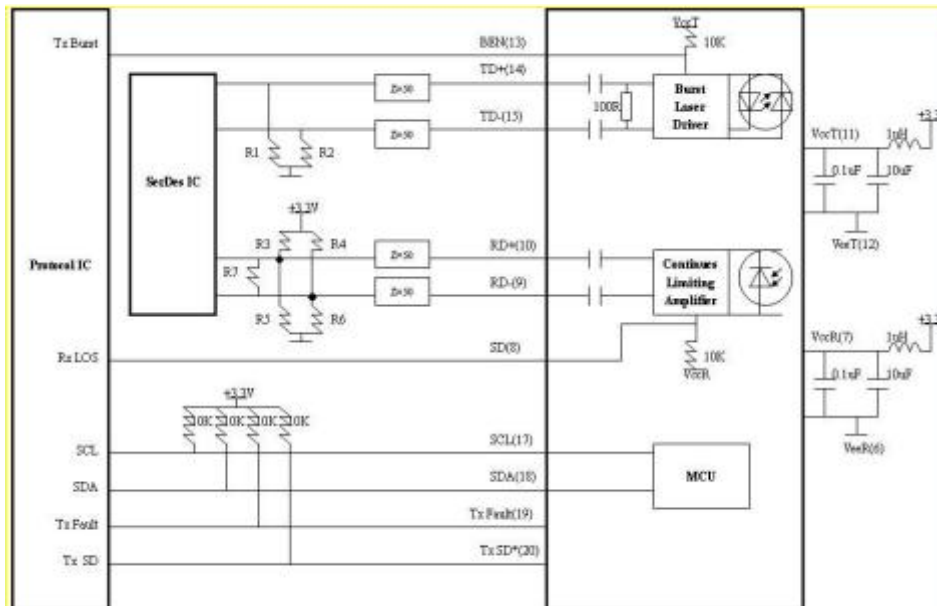

### Note:

1. If you use the no Tx\_SD function, please don't connect PIN 20 in your circuit.
  2. Tx : AC coupled internally. R1=R2=150Ω .
- Rx: AC coupled internally.

Input stage in SerDes IC with internal bias to Vcc- 1.3V

R3=R4=R5=R6=N.C, R7=100Ω

Input stage in SerDes IC without internal bias to Vcc- 1.3V R3=R4=82Ω,R5=R6=130Ω,R7=N.C

## Burst Mode Sequence Definition

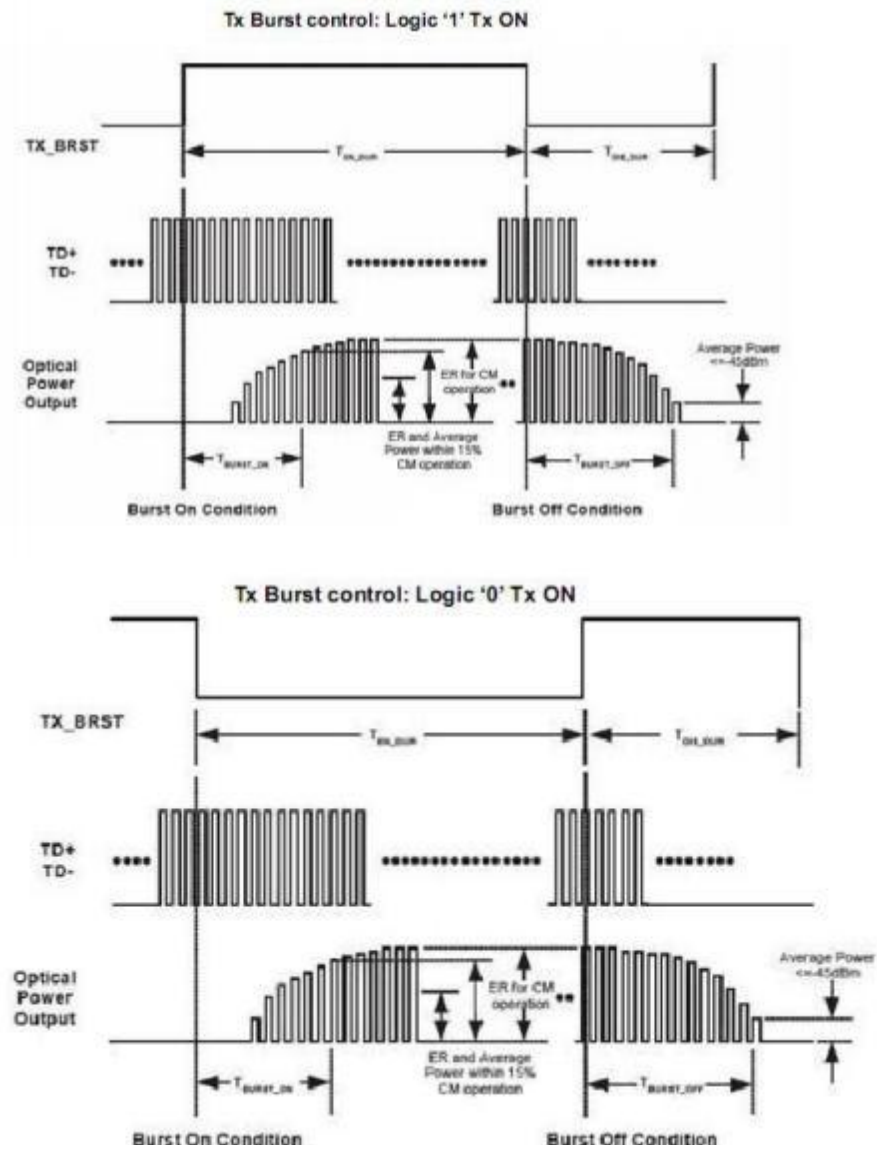

## Package Diagram

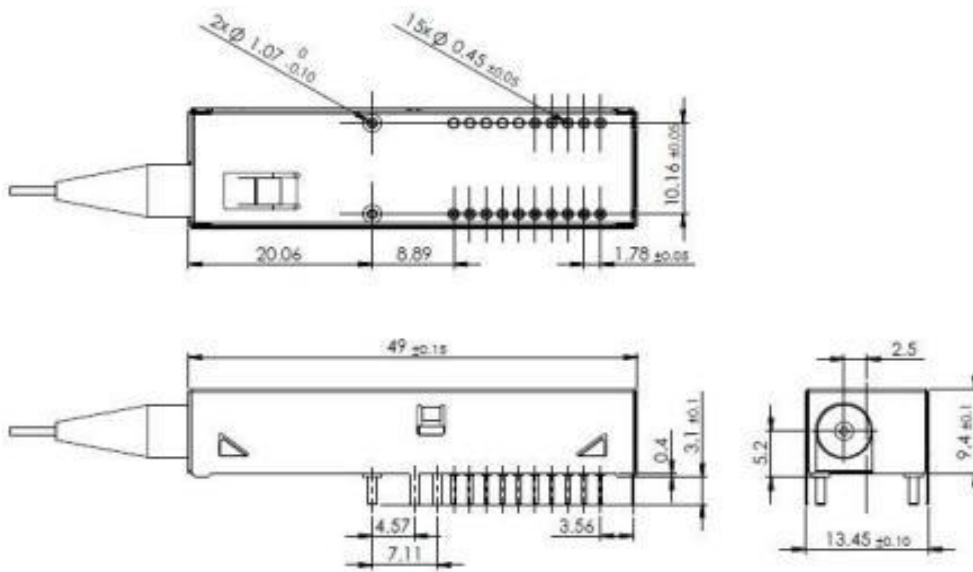

## Ordering information

Part Number	Product Description
EUF-0P11-20C	1.25G EPON ONT/ONU Tx1310nm/Rx1490nm 2x10 SFF Pigtail 20km DDM 0°C~+70°C,

AscentOptics reserves the right to make changes to the product(s) or information contained herein without notice. No liability is assumed as a result of their use or application. No rights under any patent accompany the sale of any such product(s) or information. Edition: Apr. 2019 Published by Ascent Optics Co.,Ltd. Copyright © Ascent Optics All Rights Reserved.

E-mail: [sales@ascentoptics.com](mailto:sales@ascentoptics.com)

Web : <http://www.ascentoptics.com>